



SPECIFICATION

CUSTOMER : _____

MODULE NO.: AGM 0043WT

<p>APPROVED BY: (FOR CUSTOMER USE ONLY)</p>	<p>PCB VERSION:</p>	<p>DATA:</p>
--	----------------------------	---------------------

SALES BY	APPROVED BY	CHECKED BY	PREPARED BY

VERSION	DATE	REVISED PAGE NO.	SUMMARY
0	2011.01.10		First issue

Contents

1. Module Classification Information
2. Block Diagram
3. Electrical Characteristics
4. Absolute Maximum Ratings
5. Interface Pin Function
6. DC Characteristics
7. AC Characteristics
8. Data transfer order Setting
9. Register Depiction
10. Optical Characteristics
11. Contour Drawing
12. Touch Screen Panel Specifications
13. RELIABILITY TEST

This product is composed of a TFT LCD panel, driver ICs, FPC, Control Board and a backlight unit. The following table described the features of AGM 0043WT

Item	Dimension	Unit
Dot Matrix	480 x RGBx 272(TFT)	dots
Module dimension	105.5x 67.2 x 7.8	mm
View area	95.04x 53.85	mm
Dot pitch	0.066(W) × 0.198(H) mm	mm
LCD type	TFT, Negative, Transmissive	
View direction	6 o'clock	
Backlight Type	LED, Normally White	
Controller IC	SSD1963	

*Expose the IC number blaze (Luminosity over than 1 cd) when using the LCM may cause IC operating failure.

*Color tone slight changed by temperature and driving voltage.

2. Block Diagram

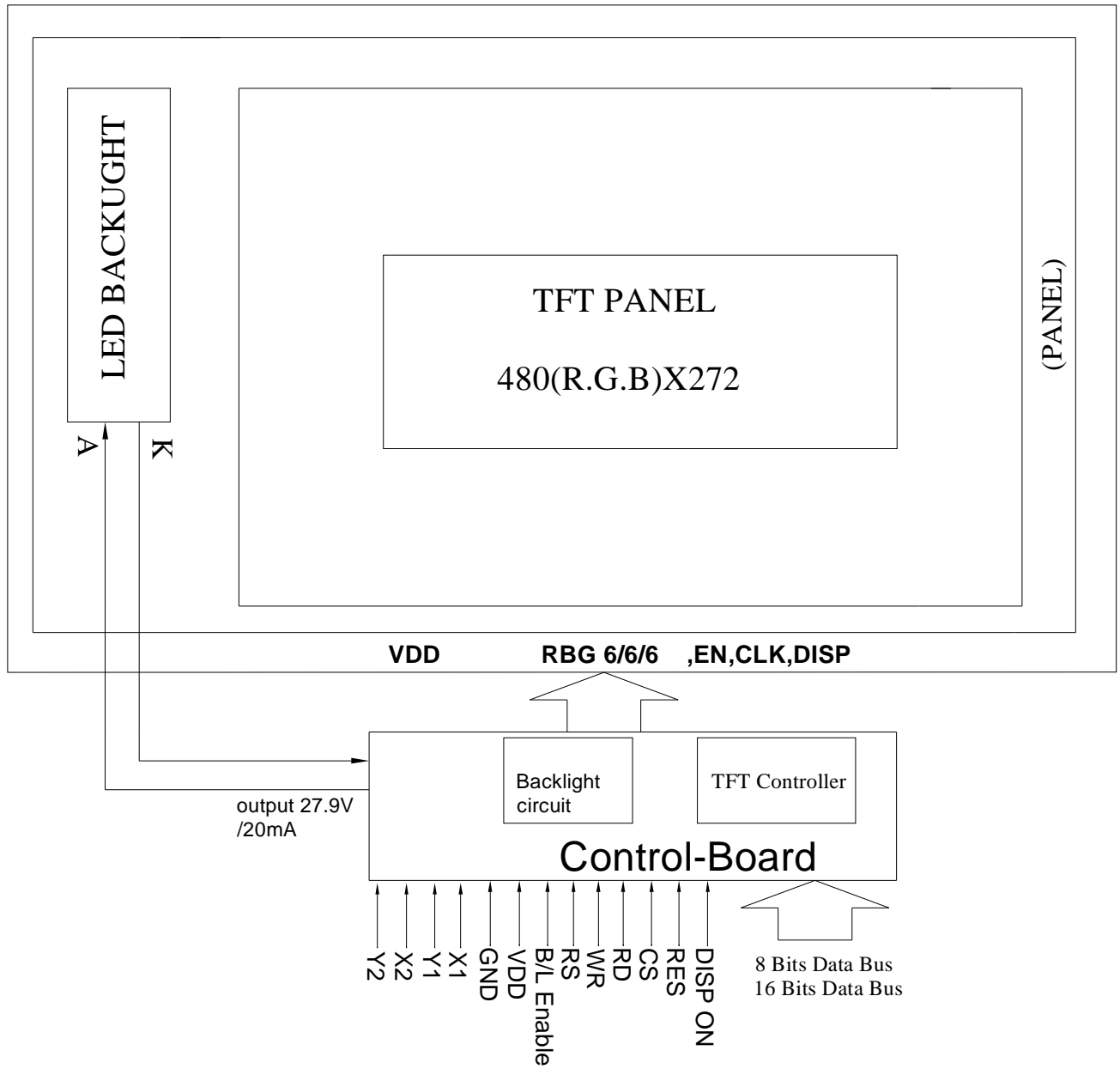

3.Electrical Characteristics

Item	Symbol	Values			Unit	Remark
		Min	TYP	max		
Operating voltage	VDD	3.1	3.3	3.5	V	
Input high voltage	VIH	0.8*VDD	-	VDD	V	
Input low voltage	VIL	0	-	0.2*VDD	V	
Output high voltage	VOH	VDD-0.3		VDD	V	
Output low voltage	VOL	0	-	0.3	V	
Current Consumption	IVCI	-	245	-	mA	
Power Consumption	PLCD	-	808.5	-	mW	

4. Absolute Maximum Ratings

Item	Symbol	Values		Unit	Remark
		Min	max		
Power Supply Voltages	VDD	-0.5	5.0	V	
Input signal voltage	Logic input	-0.5	5.0	V	
Operating Temperature	Topa	-20	70	°C	Note3,4
Storage Temperature	Tst	-30	80	°C	Note3,4
LED Reverse Voltage	Vr	-	1.2	V	Each LED Note2
LED Forward Current	IF	-	25	mA	Each LED
LED life time	--	20,000	--	--	Note5

Note 1: The absolute maximum rating values of this product are not allowed to be exceeded at any times. A module should be used with any of the absolute maximum ratings exceeded, the characteristics of the module may not be recovered, or in an extreme condition, the module may be permanently destroyed.

Note 2: VR Conditions: Zener Diode 20mA

Note 3: 90% RH Max. (Max wet temp. is 60°C)

Maximum wet-bulb temperature is at 60°C or less. And No condensation (no drops of dew)

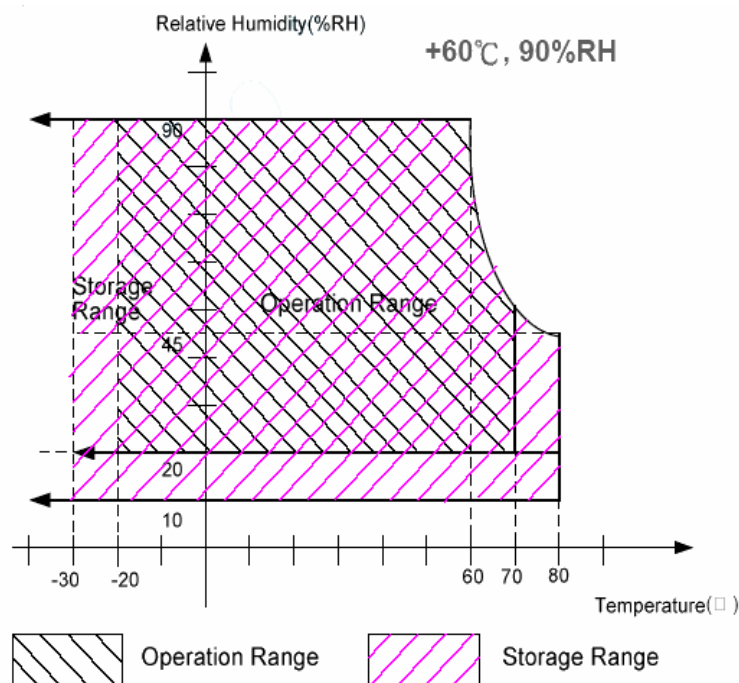

Note 4: In case of temperature below 0°C, the response time of liquid crystal (LC) becomes slower and the color of panel darker than normal one.

Note 5: The "LED life time" is defined as the module brightness decrease to 50% original brightness that the ambient temperature is 25°C and IL = 20mA. The LED lifetime could be decreased if operating IL is larger than 20 mA.

5.Interface Pin Function

5-1 Pins Connection To Control Board

P/N	Symbol	8 B IT Function
1	GND	Ground
2	VDD	Power supply for Logic
3	B/L Enable	Backlight control (H: ON L: OFF)
4	RS	Command/Data select
5	WR	8080 family MPU interface : Write signal
6	RD	8080 family MPU interface: Read signal
7	DB0	Data bus
8	DB1	
9	DB2	
10	DB3	
11	DB4	
12	DB5	
13	DB6	
14	DB7	
15	CS	Chip select
16	RES	Reset
17	NC	No connection
18	X1	Touch screen
19	DISP ON	Display on
20	Y1	Touch screen
21	X2	Touch screen
22	Y2	Touch screen

6. DC CHARACTERISTICS

Conditions:

Voltage referenced to VSS

VDDD, VDDPLL = 1.2V

VDDIO, VDDLCD = 3.3V

TA = 25°C

DC Characteristics

Symbol	Parameter	Test Condition	Min	Typ	Max	Unit
PSTY	Quiescent Power			300	500	uW
IIZ	Input leakage current		-1		1	uA
IOZ	Output leakage current		-1		1	uA
VOH	Output high voltage		0.8VDDIO			V
VOL	Output low voltage				0.2VDDIO	V
VIH	Input high voltage		0.8VDDIO		VDDIO + 0.5	V
VIL	Input low voltage				0.2VDDIO	V

7. AC Characteristics

Conditions:

Voltage referenced to VSS

VDDD, VDDPLL = 1.2V

VDDIO, VDDLCD = 3.3V

TA = 25°C

CL = 50pF (Bus/CPU Interface)

CL = 0pF (LCD Panel Interface)

7.1 Clock Timing

Table 7-1: Clock Input Requirements for CLK (PLL-bypass)

Symbol	Parameter	Min	Max	Units
FCLK	Input Clock Frequency (CLK)		110	MHz
TCLK	Input Clock period (CLK)	1/fCLK		ns

Table 7-2: Clock Input Requirements for CLK

Symbol	Parameter	Min	Max	Units
FCLK	Input Clock Frequency (CLK)	2.5	50	MHz
TCLK	Input Clock period (CLK)	1/fCLK		ns

Table 7-3: Clock Input Requirements for crystal oscillator XTAL

Symbol	Parameter	Min	Max	Units
FXTAL	Input Clock Frequency	2.5	10	MHz
TXTAL	Input Clock period	1/fXTAL		ns

7.2 MCU Interface Timing

7.2.1 Parallel 6800-series Interface Timing

Table 7-4: Parallel 6800-series Interface Timing Characteristics (Use CS# as clock)

Symbol	Parameter	Min	Typ	Max	Unit	
fMCLK	System Clock Frequency*	1	-	110	MHz	
tMCLK	System Clock Period*	1/fMCLK	-	-	ns	
tPWCSH	Control Pulse High Width	Write	13	1.5* tMCLK	-	ns
		Read	30	3.5* tMCLK		
tPWCSL	Control Pulse Low Width	Write (next write cycle)	13	1.5* tMCLK	-	ns
		Write (next read cycle)	80	9* tMCLK		
		Read	80	9* tMCLK		
tAS	Address Setup Time	2	-	-	ns	
tAH	Address Hold Time	2	-	-	ns	
tDSW	Data Setup Time	4	-	-	ns	
tDHW	Data Hold Time	1	-	-	ns	
tPLW	Write Low Time	14	-	-	ns	
tPHW	Write High Time	14	-	-	ns	
tPLWR	Read Low Time	38	-	-	ns	
tACC	Data Access Time	32	-	-	ns	
tDHR	Output Hold time	1	-	-	ns	
tR	Rise Time	-	-	0.5	ns	
tF	Fall Time	-	-	0.5	ns	

* System Clock denotes external input clock (PLL-bypass) or internal generated clock (PLL-enabled)

Figure 7-1: Parallel 6800-series Interface Timing Diagram (Use CS# as Clock)

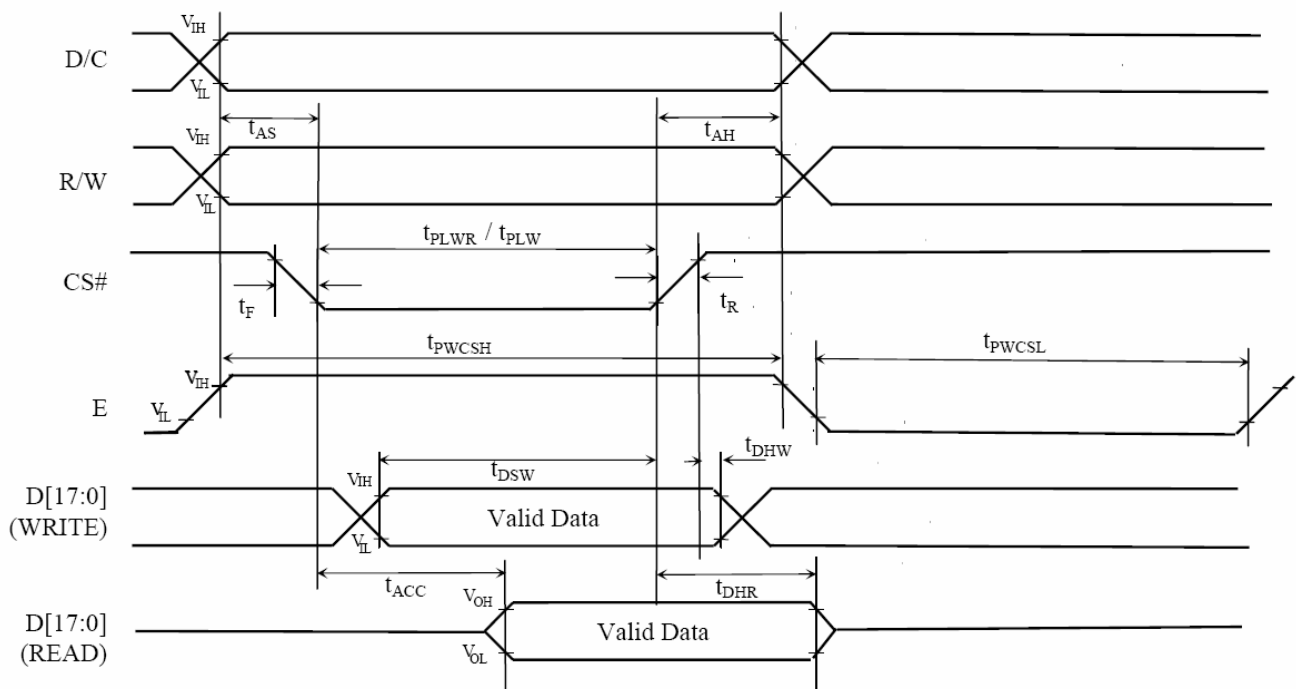
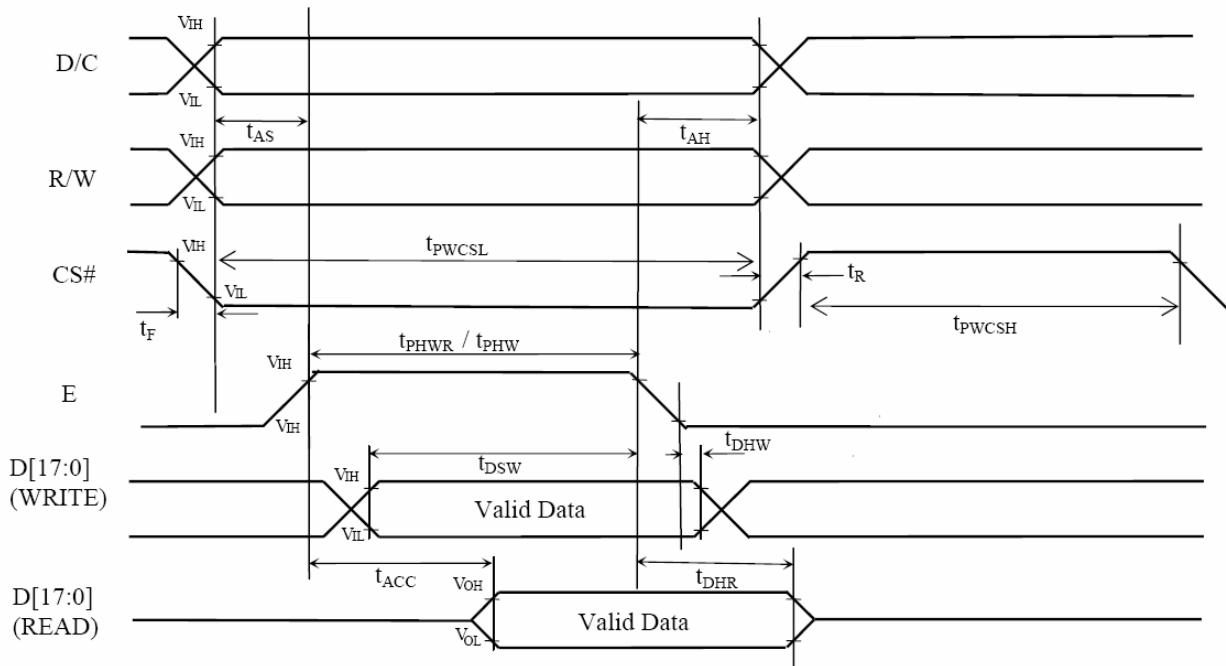

Table 7-5: Parallel 6800-series Interface Timing Characteristics (Use E as clock)

Symbol	Parameter	Min	Typ	Max	Unit	
fMCLK	System Clock Frequency*	1	-	110	MHz	
tMCLK	System Clock Period*	1/fMCLK	-	-	ns	
tPWCSH	Control Pulse Low Width	Write (next write cycle)	13	1.5* tMCLK	-	ns
		Write (next read cycle)	80	9* tMCLK		
		Read	80	9* tMCLK		
tPWCSL	Control Pulse High Width	Write	13	1.5* tMCLK	-	ns
		Read	30	3.5* tMCLK		
tAS	Address Setup Time	2	-	-	ns	
tAH	Address Hold Time	2	-	-	ns	
tDSW	Data Setup Time	4	-	-	ns	
tDHW	Data Hold Time	1	-	-	ns	
tPLW	Write Low Time	14	-	-	ns	
tPHW	Write High Time	14	-	-	ns	
tPLWR	Read Low Time	38	-	-	ns	
tACC	Data Access Time	32	-	-	ns	
tDHR	Output Hold time	1	-	-	ns	
tR	Rise Time	-	-	0.5	ns	
tF	Fall Time	-	-	0.5	ns	

* System Clock denotes external input clock (PLL-bypass) or internal generated clock (PLL-enabled)

Figure7-2: Parallel 6800-series Interface Timing Diagram (Use E as Clock)



7.2.2 Parallel 8080-series Interface Timing

Table 7-6: Parallel 8080-series Interface

Symbol	Parameter	Min	Typ	Max	Unit
fMCLK	System Clock Frequency*	1	-	110	MHz
tMCLK	System Clock Period*	1/ fMCLK	-	-	ns
tPWCSL	Control Pulse High Width	Write 13 Read 30	1.5* tMCLK 3.5* tMCLK	-	ns
tPWCSH	Control Pulse Low Width	Write (next write cycle) 13 Write (next read cycle) 80 Read 80	1.5* tMCLK 9* tMCLK 9* tMCLK	-	ns
tAS	Address Setup Time	1	-	-	ns
tAH	Address Hold Time	2	-	-	ns
tDSW	Write Data Setup Time	4	-	-	ns
tDHW	Write Data Hold Time	1	-	-	ns
tPWLW	Write Low Time	12	-	-	ns
tDHR	Read Data Hold Time	1	-	-	ns
tACC	Access Time	32	-	-	ns
tPWLR	Read Low Time	36	-	-	ns
tR	Rise Time	-	-	0.5	ns
tF	Fall Time	-	-	0.5	ns
tCS	Chip select setup time	2	-	-	ns
tCSH	Chip select hold time to read signal	3	-	-	ns

* System Clock denotes external input clock (PLL-bypass) or internal generated clock (PLL-enabled)

Figure 7-3: Parallel 8080-series Interface Timing Diagram (Write Cycle)

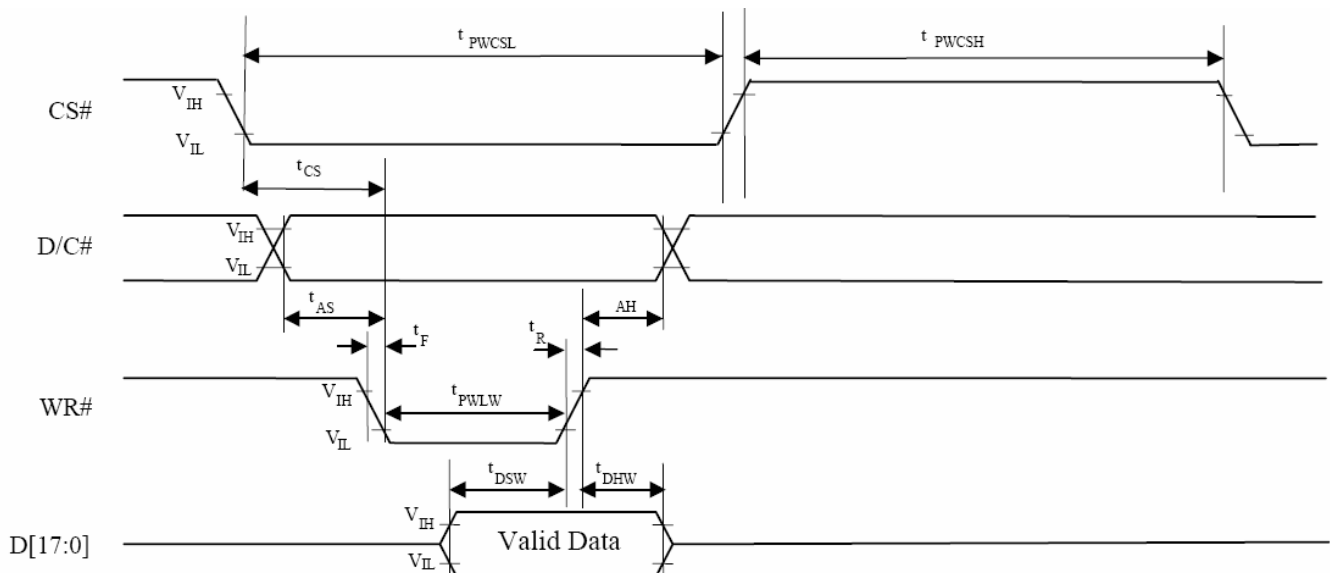
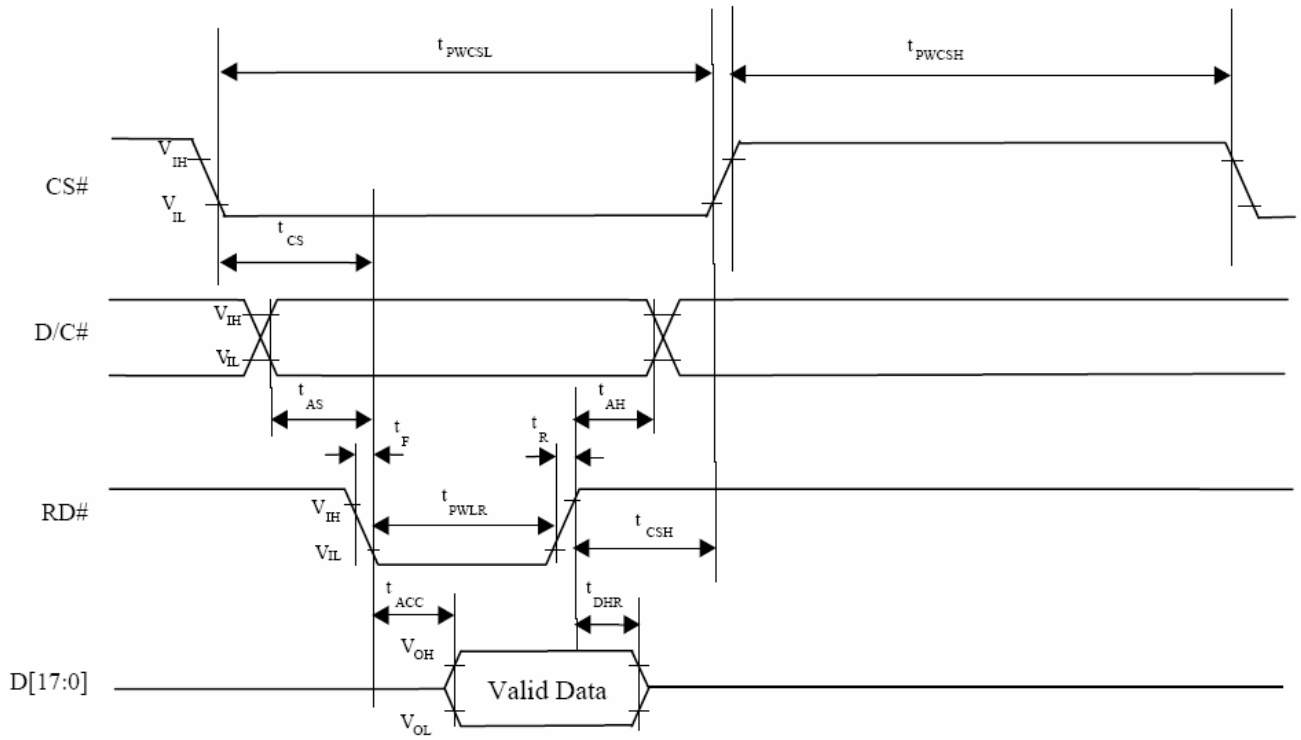

Figure 7-4: Parallel 8080-series Interface Timing Diagram (Read Cycle)



8. Data transfer order Setting

Pixel Data Format

Both 6800 and 8080 support 8-bit, 9-bit, 16-bit, 18-bit and 24-bit data bus. Depending on the width of the data bus, the display data are packed into the data bus in different ways.

Table 8-1: Pixel Data Format

Interface	Cycle	D[23]	D[22]	D[21]	D[20]	D[19]	D[18]	D[17]	D[16]	D[15]	D[14]	D[13]	D[12]	D[11]	D[10]	D[9]	D[8]	D[7]	D[6]	D[5]	D[4]	D[3]	D[2]	D[1]	D[0]
24 bits	1st	R7	R6	R5	R4	R3	R2	R1	R0	G7	G6	G5	G4	G3	G2	G1	G0	B7	B6	B5	B4	B3	B2	B1	B0
18 bits	1st							R5	R4	R3	R2	R1	R0	G5	G4	G3	G2	G1	G0	B5	B4	B3	B2	B1	B0
16 bits (565 format)	1st									R5	R4	R3	R2	R1	G5	G4	G3	G2	G1	G0	B5	B4	B3	B2	B1
16 bits	1st									R7	R6	R5	R4	R3	R2	R1	R0	G7	G6	G5	G4	G3	G2	G1	G0
	2nd									B7	B6	B5	B4	B3	B2	B1	B0	R7	R6	R5	R4	R3	R2	R1	R0
	3rd									G7	G6	G5	G4	G3	G2	G1	G0	B7	B6	B5	B4	B3	B2	B1	B0
12 bits	1st													R7	R6	R5	R4	R3	R2	R1	R0	G7	G6	G5	G4
	2nd													G3	G2	G1	G0	B7	B6	B5	B4	B3	B2	B1	B0
9 bits	1st																R5	R4	R3	R2	R1	R0	G5	G4	G3
	2nd																G2	G1	G0	B5	B4	B3	B2	B1	B0
8 bits	1st																	R7	R6	R5	R4	R3	R2	R1	R0
	2nd																	G7	G6	G5	G4	G3	G2	G1	G0
	3rd																	B7	B6	B5	B4	B3	B2	B1	B0

9 Register Depiction

Please consult the spec of SSD1963 Version 1.2

10. OPTICAL CHARACTERISTIC

Item	Symbol	Condition	Values			Unit	Remark
			Min.	Typ.	Max.		
Viewing angle (CR \geq 10)	θ_L	$\varphi=180^0$ (9 o'clock)	60	70	—	degree	Note1
	θ_R	$\varphi=0^0$ (3 o'clock)	60	70	—		
	θ_T	$\varphi=90^0$ (12 o'clock)	40	50	—		
	θ_B	$\varphi=270^0$ (6 o'clock)	60	70	—		
Response time	T _{ON}	Normal $\theta = \varphi = 0^0$	—	10	20	msec	Note 3
	T _{OFF}		—	15	30	msec	Note 3
Contrast ratio	CR		400	500	—	—	Note 4
Color chromaticity	W _X		0.26	0.31	0.36	—	Note 2 Note 5 Note 6
	W _Y		0.28	0.33	0.38	—	
Luminance	L		350	400	—	Cd/m ²	Note 6
Luminance uniformity	Yu		70	75	—	%	Note 7

Note 1: Definition of viewing angle range

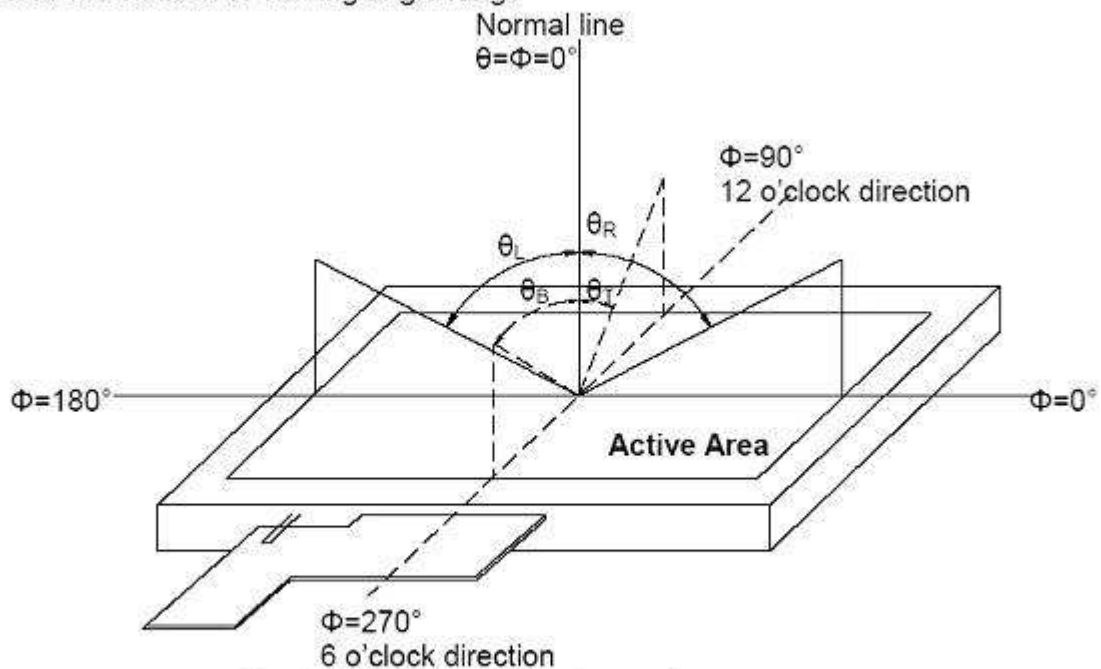

Fig. 4-1 Definition of viewing angle

Note 2: Definition of optical measurement system.

The optical characteristics should be measured in dark room. After 30 minutes operation, the optical properties are measured at the center point of the LCD screen. (Response time is measured by Photo detector TOPCON BM-7, other items are measured by BM-5A/Field of view: 1° /Height: 500mm.)

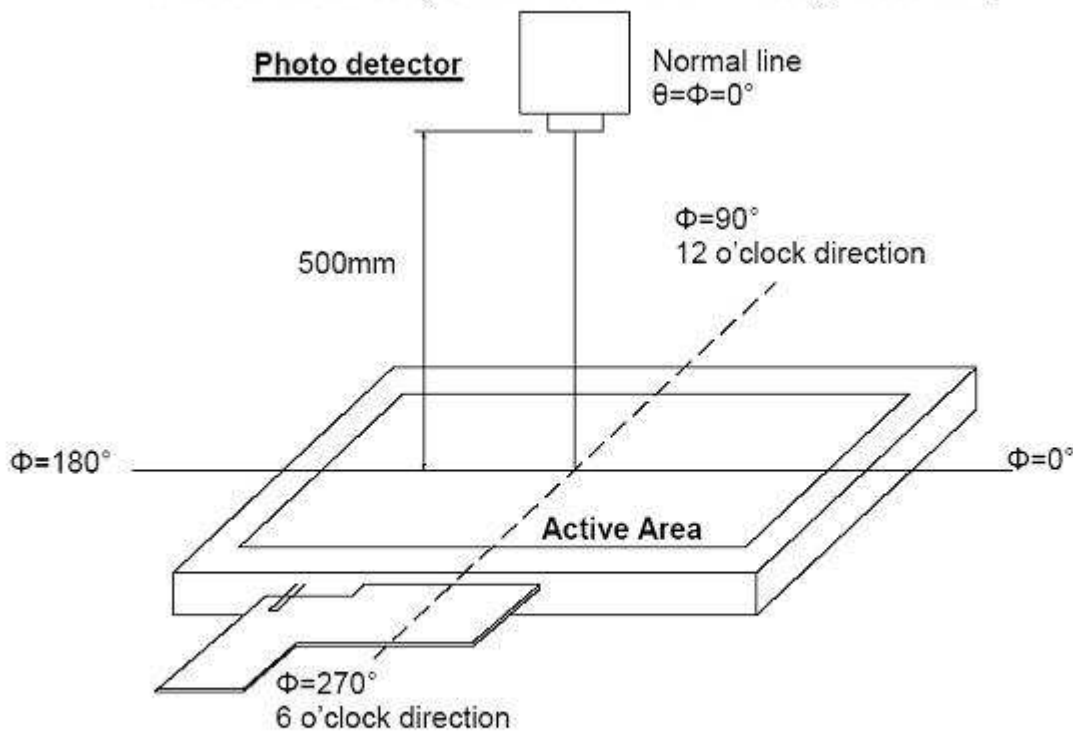

Fig. 4-2 Optical measurement system setup

Note 3: Definition of Response time

The response time is defined as the LCD optical switching time interval between "White" state and "Black" state. Rise time (T_{ON}) is the time between photo detector output intensity changed from 90% to 10%. And fall time (T_{OFF}) is the time between photo detector output intensity changed from 10% to 90%.

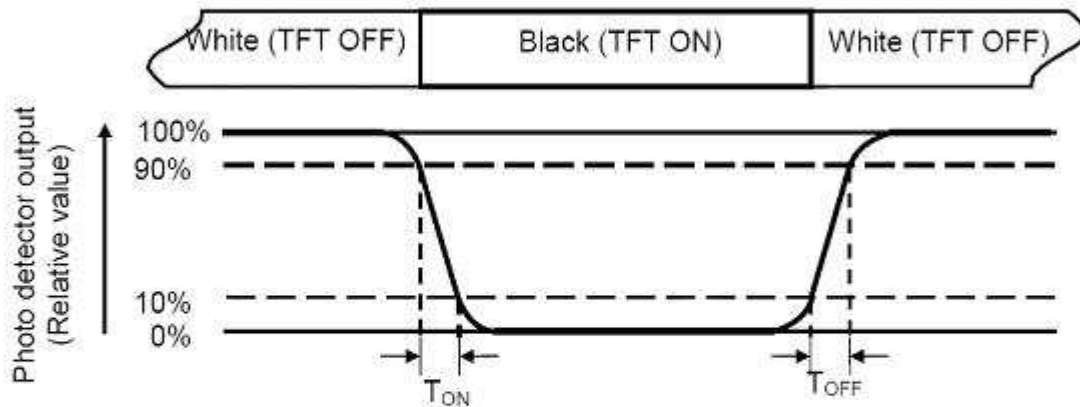

Fig. 4-3 Definition of response time

Note 4: Definition of contrast ratio

$$\text{Contrast ratio (CR)} = \frac{\text{Luminance measured when LCD on the "White" state}}{\text{Luminance measured when LCD on the "Black" state}}$$

Note 5: Definition of color chromaticity (CIE1931)

Color coordinates measured at center point of LCD.

Note 6: All input terminals LCD panel must be ground while measuring the center area of the panel. The LED driving condition is $I_L=20\text{mA}$.

Note 7: Definition of Luminance Uniformity

Active area is divided into 9 measuring areas (Refer to Fig. 4-4).Every measuring point is placed at the center of each measuring area.

$$\text{Luminance Uniformity (Yu)} = \frac{B_{\min}}{B_{\max}}$$

L-----Active area length W----- Active area width

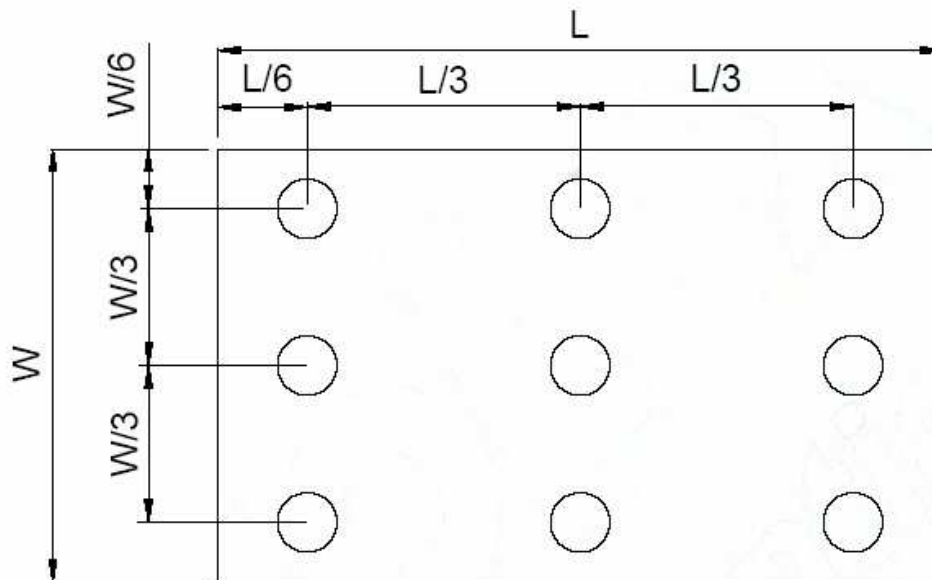
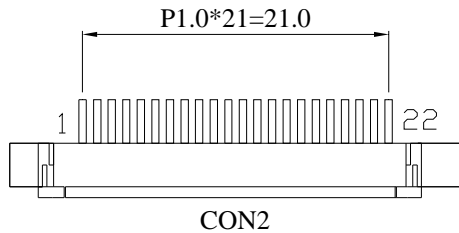
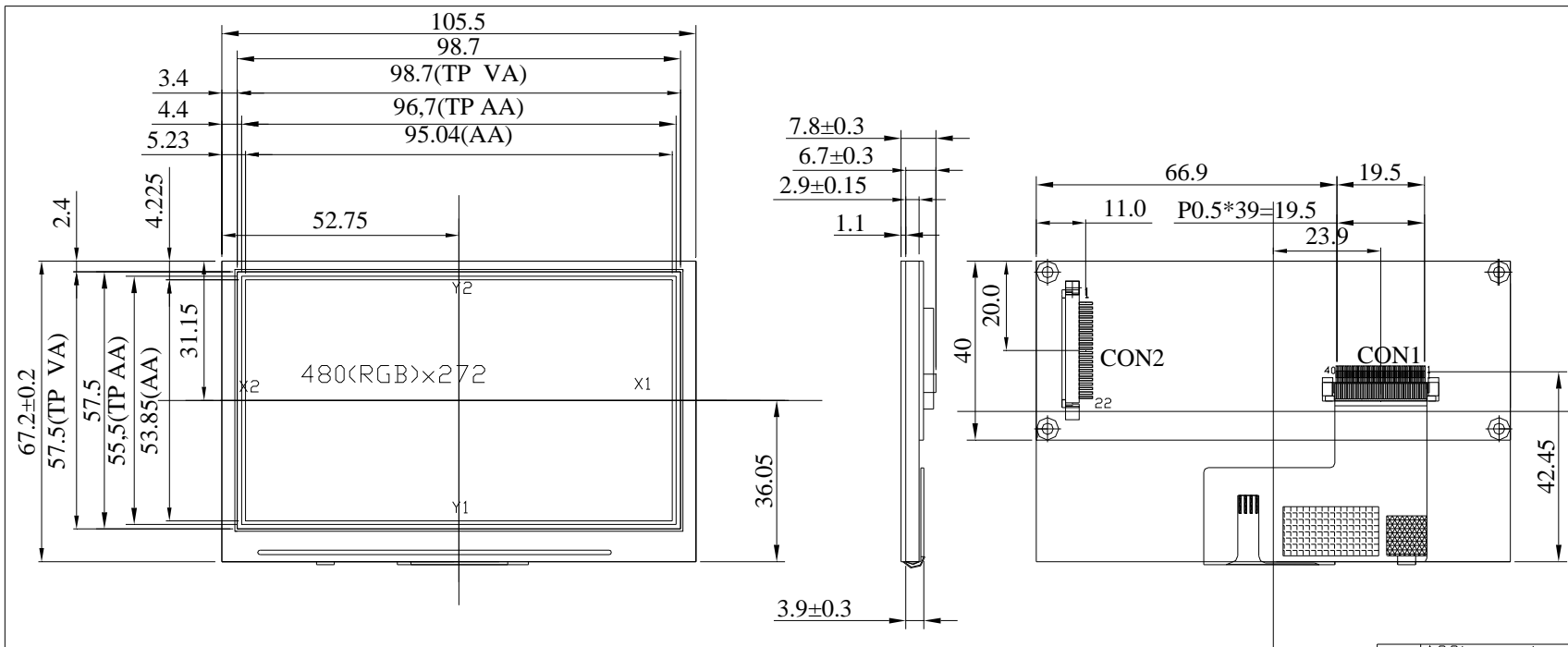

Fig. 4-4 Definition of measuring points

B_{\max} : The measured maximum luminance of all measurement position.

B_{\min} : The measured minimum luminance of all measurement position.

11. Contour Drawing



The non-specified tolerance of dimension is ±0.2mm.

PIN	ASSIGNMENT
1	GND
2	VDD
3	B/L Enable
4	RS
5	WR
6	RD
7	DB0
8	DB1
9	DB2
10	DB3
11	DB4
12	DB5
13	DB6
14	DB7
15	CS
16	RES
17	NC
18	X1
19	DISP_ON
20	Y1
21	X2
22	Y2

12.Touch Screen Panel Specifications

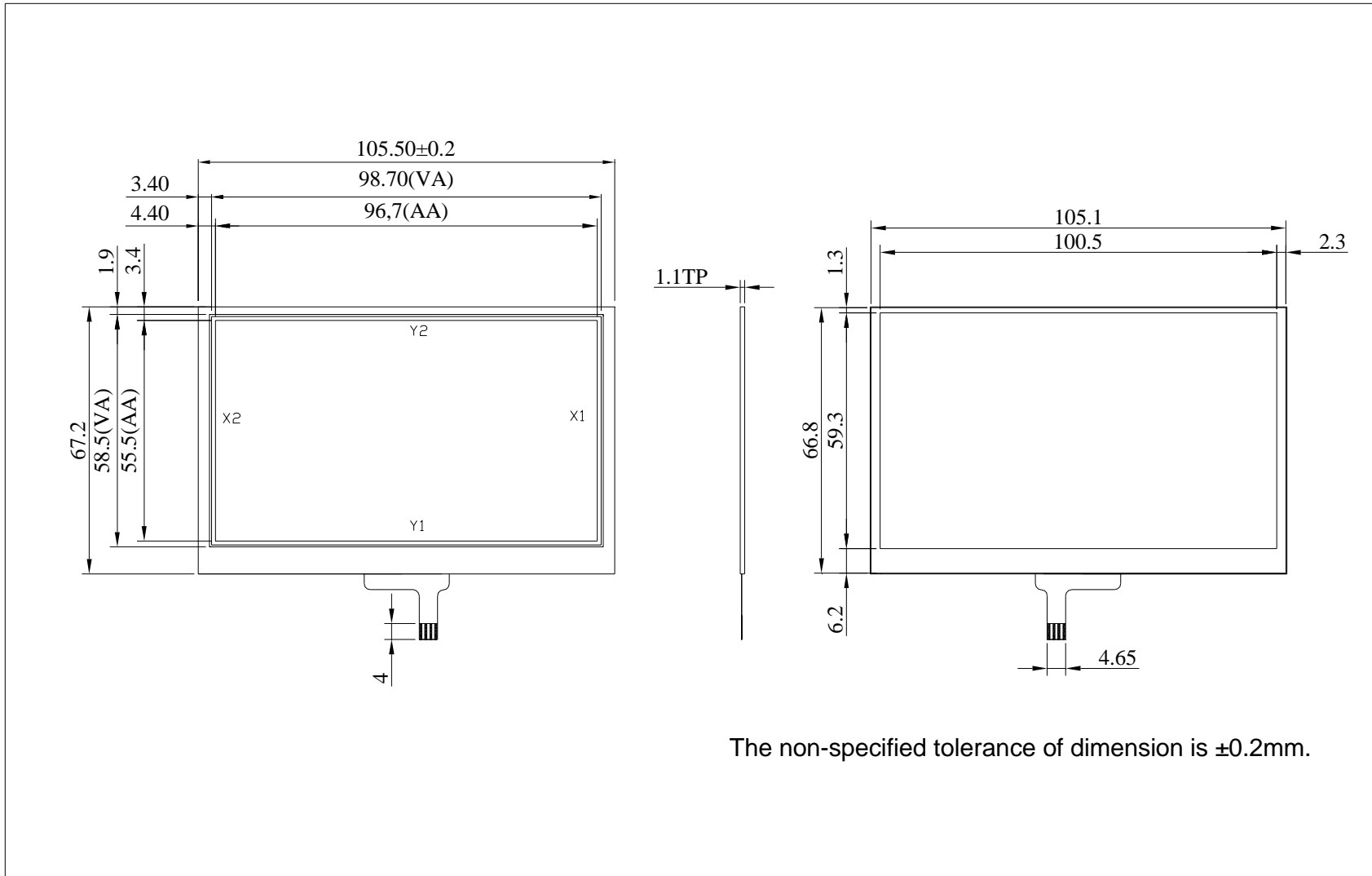

Non-Proper Ways to handle the touch screen

1. Do not pull or crease the tail of the touch screen.
2. Tails, unless the drawing calls out for a bend, are to be free of permanent creases in the polyester,
3. slight crease lines in the adhesive tail cover are allowed.

13. RELIABILITY TEST

WIDE TEMPERATURE RELIABILITY TEST

N O.	ITEM	CONDITION			STANDARD	NOTE
1	High Temp. Storage	80°C	240 Hrs		Appearance without defect	
2	Low Temp. Storage	-30°C	240 Hrs		Appearance without defect	
3	High Temp. & High Humi. Storage	60 °C 90%RH	240 Hrs		Appearance without defect	
4	High Temp. Operating Display	70°C	240 Hrs		Appearance without defect	
5	Low Temp. Operating Display	-20°C	240 Hrs		Appearance without defect	
6	Thermal Shock	-20 °C, 30min. → 70°C, 30min. ↑ (1cycle) ↓			Appearance without defect	10 cycles

Inspection Provision

1. Purpose

The AGTechnol inspection provision provides outgoing inspection provision and its expected quality level based on our outgoing inspection of WINSTAR LCD produces.

2. Applicable Scope

The AGTechno inspection provision is applicable to the arrangement in regard to outgoing inspection and quality assurance after outgoing.

3. Technical Terms

3-1 AGT Technical Terms



4. Outgoing Inspection

4-1 Inspection Method

MIL-STD-105E Level II Regular inspection

4-2 Inspection Standard

	Item	AQL(%)	Remarks
Major Defect	Dots Opens Shorts Erroneous operation	0.4	Faults which substantially lower the practicality and the initial purpose difficult to achieve
	Solder appearance Shorts Loose		
	Cracks Display surface cracks		

	Dimensions	External from Dimensions	AQL	
Minor Defect	Inside the glass	Black spots	0.65	Faults which appear to pose almost no obstacle to the practicality, effective use, and operation
	Polarizing plate	Scratches, foreign Matter, air bubbles, and peeling		
	Dots	Pinhole, deformation		
	Color tone	Color unevenness		
	Solder appearance	Cold solder Solder projections		

4-3 Inspection Provisions

*Viewing Area Definition

Fig. 1

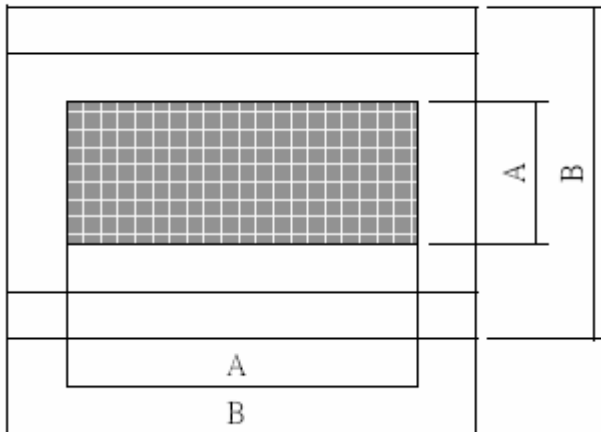

A : Zone Viewing Area

B : Zone Glass Plate Outline

*Inspection place to be 500 to 1000 lux illuminance uniformly without glaring.

The distance between luminous source(daylight fluorescent lamp and cool white fluorescent lamp) and sample to be 30 cm to 50 cm.

*Test and measurement are performed under the following conditions, unless otherwise specified.

Temperature $20 \pm 15^{\circ}\text{C}$

Humidity $65 \pm 20\% \text{R.H.}$

Pressure 860~1060hPa(mmbar)

In case of doubtful judgment, it is performed under the following conditions.

Temperature $20 \pm 2^{\circ}\text{C}$

Humidity $65 \pm 5\% \text{R.H.}$

Pressure 860~1060hPa(mmbar)

5.Specification for quality check

5-1-1 Electrical characteristics :

NO.	Item	Criterion
1	Non operational	Fail
2	Miss operating	Fail
3	Contrast irregular	Fail
4	Response time	Within Specified value

5-1-2 Components soldering :

Should be no defective soldering such as shorting, loose terminal cold solder, peeling of printed circuit board pattern, improper mounting position, etc.

5-2 Inspection Standard for TFT panel

5-2-1 The environmental condition of inspection :

The environmental condition and visual inspection shall be conducted as below.

(1) Ambient temperature : $25 \pm 5^{\circ}\text{C}$

(2) Humidity : 25~75% RH

(3) External appearance inspection shall be conducted by using a single 20W fluorescent lamp or equivalent illumination.

(4) Visual inspection on the operation condition for cosmetic shall be conducted at the distance 30cm or more between the LCD panels and eyes of inspector. The viewing angle shall be 90 degree to the front surface of display panel.

(5) Ambient Illumination : 300~500 Lux for external appearance inspection.

(6) Ambient Illumination : 100~200 Lux for light on inspection.

5-2-2 Inspection Criteria

(1) Definition of dot defect induced from the panel inside

a) The definition of dot : The size of a defective dot over 1/2 of whole dot is regarded as one defective dot

b) Bright dot : Dots appear bright and unchanged in size in which LCD panel is displaying under black pattern.

c) Dark dot : Dots appear dark and unchanged in size in which LCD panel is displaying under pure red, green, blue pattern.

d) 2 dot adjacent = 1 pair = 2 dots

Picture :

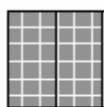

2 dot adjacent



2 dot adjacent (vertical)

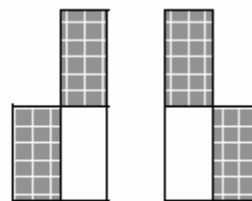

2 dot adjacent (slant)

(2) Display Inspection

NO.	Item		Acceptable Count	
1	Dot defect	Bright Dot	Random	$N \leq 2$
			2 dots adjacent	$N \leq 0$
		Dark Dot	Random	$N \leq 3$
			2 dots adjacent	$N \leq 1$
	Total bright and dark dot		$N \leq 4$	
Functional failure (V-line/ H-line/Cross line etc.)		Not allowable		
	Mura	It's OK if mura is slight visible through 6% ND filter. (Judged by limit sample if it is necessary)		
2	Newton ring (touch panel)	Orbicular of interference fringes is not allowed in the optimum contrast within the active area under viewing angle.		

(3) Appearance inspection

NO.	Item	Standards
1	Panel Crack	Not allow. It is shown in Fig.1.
2	Broken CF Non -lead Side of TFT	The broken in the area of $W > 2\text{mm}$ is ignored, L is ignored. It is shown in Fig.2.
3	Broken Lead Side of TFT	FPC lead, electrical line or alignment mark can't be damaged. It is shown in Fig.3.
4	Broken Corner of TFT at Lead Side	FPC lead. electrical line or alignment mark can't be damaged. It is shown in Fig.4.
5	Burr of TFT / CF Edge	The distance of burr from the edge of TFT / CF, $W \leq 0.3\text{mm}$. It is shown in Fig.5.
6	Foreign Black / White/Bright Spot	(1) $0.15 < D \leq 0.5 \text{ mm}$, $N \leq 4$; (2) $D \leq 0.15\text{mm}$, Ignore. It is shown in Fig.6.
7	Foreign Black / White/Bright Line	(1) $0.05 < W \leq 0.1 \text{ mm}$, $0.3 < L \leq 2 \text{ mm}$, $N \leq 4$.
		(2) $W \leq 0.05\text{mm}$ and $L \leq 0.3\text{mm}$ Ignore. It is shown in Fig.7.
8	Color irregular	Not remarkable color irregular.

Fig 1.

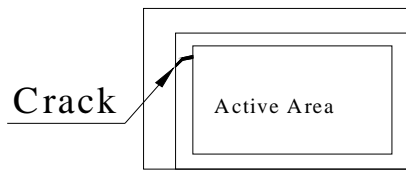

Fig 2.

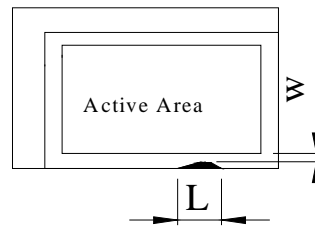

Fig 3.

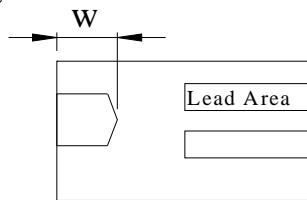

Fig 4.

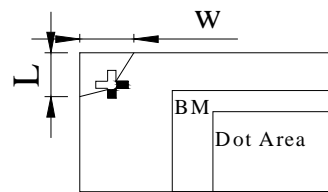

Fig 5.

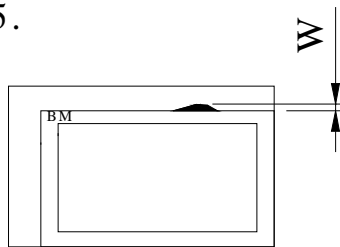
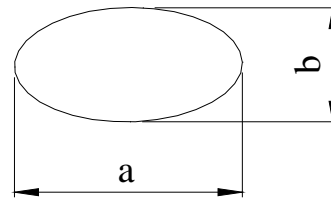

Fig 6.



$$D = (a+b)/2$$

Fig 7.

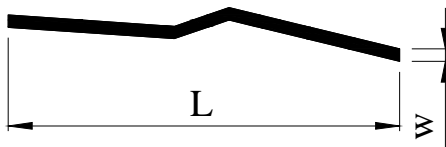
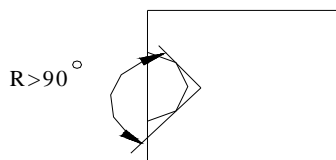

Fig8.



Notes

1.W:Width

2.Length

3.D:Average Diameter

4.N:Count

5.All the anhle of the broken must be larger than 90~.It is shown in Fig.8.(R>90~)

NOTICE:

- SAFETY

1. If the LCD panel breaks, be careful not to get the liquid crystal to touch your skin.
2. If the liquid crystal touches your skin or clothes, please wash it off immediately by using soap and water.

- HANDLING

1. Avoid static electricity which can damage the CMOS LSI.
2. Do not remove the panel or frame from the module.
3. The polarizing plate of the display is very fragile. So, please handle it very carefully.
4. Do not wipe the polarizing plate with a dry cloth, as it may easily scratch the surface of plate.
5. Do not use ketonics solvent & Aromatic solvent. Use a soft cloth soaked with a cleaning naphtha solvent.

- STORAGE

1. Store the panel or module in a dark place where the temperature is $25\pm 5^{\circ}\text{C}$ and the humidity is below 65% RH.
2. Do not place the module near organics solvents or corrosive gases.
3. Do not crush, shake, or jolt the module.

- TERMS OF WARRANT

1. Acceptance inspection period

The period is within one month after the arrival of contracted commodity at the buyer's factory site.

2. Applicable warrant period

The period is within twelve months since the date of shipping out under normal using and storage conditions.